

# MICHIGAN

WELDING CO.

## 180A ARC MIG TIG WELDER

PART NO: MULTI180 (..123256)



TO PREVENT SERIOUS INJURY, READ  
AND UNDERSTAND ALL WARNINGS  
AND INSTRUCTIONS BEFORE USE.

**OPERATING  
INSTRUCTIONS**

# CONTENTS

GENERAL SAFETY RULES.....	3
PROPER CARE, MAINTENANCE AND REPAIR .....	8
DESCRIPTION .....	9
INSTALLATION .....	12
MIG GMAW OPERATION.....	18
ARC MMA OPERATION .....	25
TIG GTAW OPERATION .....	30
TIG MAINTENANCE, SERVICE TIPS AND ADVICE .....	33
SERVICE, MAINTENANCE, TRANSPORTATION & STORAGE .....	36
MULTI180 TROUBLE SHOOTING CHART .....	38
MAIN CIRCUIT CHART .....	39
PARTS BREAKDOWN .....	40
NOTES .....	42
WARRANTY INFORMATION.....	44

# SAVE THESE INSTRUCTIONS

## GENERAL SAFETY RULES

**WARNING: Read and understand all instructions.** Failure to follow all instructions listed below may result in serious injury.



### CAUTION

Do not allow persons to operate or assemble this MULTI180 until they have read this manual and have developed a thorough understanding of how the MULTI180



### WARNING

The warnings, cautions, and instructions discussed in this instruction manual cannot cover all possible conditions or situations that could occur. It must be understood by the operator that common sense and caution are factors which cannot be built into this product, but must be supplied by the operator.

## IMPORTANT SAFETY CONSIDERATIONS

### Your Welding Environment

- Keep the environment you will be welding in free from flammable materials.
- Always keep a fire extinguisher close to your welding environment.
- Always have a qualified person install and operate this equipment.
- Make sure the area is clean, dry and well ventilated. Do not operate the welder in humid, wet or poorly ventilated areas.
- Always have your welder maintained by a qualified technician in accordance with local, state and national codes.
- Always be aware of your work environment. Be sure to keep other people, especially children, away from you while welding.
- Keep harmful arc rays shielded from the view of others.
- Mount the welder on a secure bench or cart that will keep the welder secure and prevent it from tipping over or falling.

## **Your Machine's Condition**

- Check ground cable, power cord and welding cable to be sure the insulation is not damaged. Always replace or repair damaged components before using the welder.
- Check all components to ensure they are clean and in good operating condition before use.

## **Use of Your Machine**

- Do not operate the welder if the output cable, electrode, MIG gun, wire or wire feed system is wet. Do not immerse them in water. These components and the welder must be completely dry before attempting to use them.
- Follow the instructions in this manual.
- Keep welder in the off position when not in use.
- Connect ground lead as close to the area being welded as possible to ensure a good ground.
- Do not allow any body part to come in contact with the welding wire if you are in contact with the material being welded, ground or electrode from another welder.
- Do not weld if you are in an awkward position. Always have a secure stance while welding to prevent accidents. Wear a safety harness if working above ground.
- Do not drape cables over or around your body.
- Wear a full coverage helmet with appropriate shade (see ANSI Z87.1 safety standard) and safety glasses while welding.
- Wear proper gloves and protective clothing to prevent your skin from being exposed to hot metals, UV and IR rays.
- Do not overuse or overheat your welder. Allow proper cooling time between duty cycles.
- Keep hands and fingers away from moving parts and stay away from the drive rolls.
- Do not point MIG gun at any body part of yourself or anyone else.
- Always use this welder in the rated duty cycle to prevent excessive heat and failure.



## Specific Areas of Danger, Caution or Warning

### Electrical Shock



- Electric arc machines can produce a shock that can cause injury or death. Touching electrically live parts can cause fatal shocks and severe burns. While cutting, all metal components connected to the wire are electrically hot. Poor ground connections are a hazard, so secure the ground lead before cutting.
- Wear dry protective apparel: coat, shirt, gloves and insulated footwear.
- Insulate yourself from the work piece. Avoid contacting the work piece or ground.
- Do not attempt to repair or maintain the welder while the power is on.
- Inspect all cables and cords for any exposed wire and replace immediately if found.
- Use only recommended replacement cables and cords.
- Always attach ground clamp to the work piece or work table as close to the weld area as possible.
- Do not touch the welding wire and the ground or grounded work piece at the same time.
- Do not use a welder to thaw frozen pipes.



### Fumes and Gases

- Fumes emitted from the welding process displace clean air and can result in injury or death.
- Do not breathe in fumes emitted by the welding process. Make sure your breathing air is clean and safe.
- Work only in a well-ventilated area or use a ventilation device to remove welding fumes from the environment where you will be working.
- Do not weld on coated materials (galvanized, cadmium plated or containing zinc, mercury or barium). They will emit harmful fumes that are dangerous to breathe. If necessary use a ventilator, respirator with air supply or remove the coating from the material in the weld area.
- The fumes emitted from some metals when heated are extremely toxic. Refer to the material safety data sheet for the manufacturer's instructions.
- Do not weld near materials that will emit toxic fumes when heated. Vapours from cleaners, sprays and degreasers can be highly toxic when heated.



## UV and IR Arc Rays

- The welding arc produces ultraviolet (UV) and infrared (IR) rays that can cause injury to your eyes and skin. Do not look at the welding arc without proper eye protection.
- Always use a helmet that covers your full face from the neck to top of head and to the back of each ear.
- Use a lens that meets ANSI standards and safety glasses. For welders under 160 Amps output, use a shade 10 lens; for above 160 Amps, use a shade 12. Refer to the ANSI standard Z87.1 for more information.
- Cover all bare skin areas exposed to the arc with protective clothing and shoes. Flame-retardant cloth or leather shirts, coats, pants or coveralls are available for protection.
- Use screens or other barriers to protect other people from the arc rays emitted from your welding.
- Warn people in your welding area when you are going to strike an arc so they can protect themselves.



## Fire Hazards

- Do not weld on containers or pipes that contain or have had flammable, gaseous or liquid combustibles in them. Welding creates sparks and heat that can ignite flammable and explosive materials.
- Do not operate any electric arc welder in areas where flammable or explosive materials are present.
- Remove all flammable materials within 35 feet of the welding arc. If removal is not possible, tightly cover them with fireproof covers.
- Take precautions to ensure that flying sparks do not cause fires or explosions in hidden areas, cracks or areas you cannot see.
- Keep a fire extinguisher close in the case of fire.
- Wear garments that are oil-free with no pockets or cuffs that will collect sparks.
- Do not have on your person any items that are combustible, such as lighters or matches.
- Keep work lead connected as close to the weld area as possible to prevent any unknown, unintended paths of electrical current from causing electrical shock and fire hazards.
- To prevent any unintended arcs, cut wire back to ¼" stick out after welding.



### **Hot Materials**

- Welded materials are hot and can cause severe burns if handled improperly.
- Do not touch welded materials with bare hands.
- Do not touch MIG gun nozzle after welding until it has had time to cool down.



### **Sparks/Flying Debris**

- Welding creates hot sparks that can cause injury. Chipping slag off welds creates flying debris.
- Wear protective apparel at all times: ANSI-approved safety glasses or shield, welder's hat and ear plugs to keep sparks out of ears and hair.



### **Electromagnetic Field**

- Electromagnetic fields can interfere with various electrical and electronic devices such as pacemakers.
- Consult your doctor before using any electric arc welder or cutting device
- Keep people with pacemakers away from your welding area when welding.
- Do not wrap cable around your body while welding.
- Wrap MIG gun and ground cable together whenever possible.
- Keep MIG gun and ground cables on the same side of your body.



### **Shielding Gas Cylinders Can Explode**

- High pressure cylinders can explode if damaged, so treat them carefully.
- Never expose cylinders to high heat, sparks, open flames, mechanical shocks or arcs.
- Do not touch cylinder with MIG gun.
- Do not weld on the cylinder
- Always secure cylinder upright to a cart or stationary object.
- Keep cylinders away from welding or electrical circuits.
- Use the proper regulators, gas hose and fittings for the specific application.
- Do not look into the valve when opening it.
- Use protective cylinder cap whenever possible

# PROPER CARE, MAINTENANCE AND REPAIR



## WARNING

Always have power disconnected when working on internal components.

Do not touch or handle PC board without being properly grounded with a wrist strap. Put PC board in static proof bag to move or ship.

Do not put hands or fingers near moving parts such as drive rolls of fan.

## MULTI180 Use and Care

Do not modify the MULTI180 in any way. Unauthorized modification may impair the function and/or safety and could affect the life of the equipment. There are specific applications for which the MULTI180 was designed.

- Always check of damaged or worn out parts before using the MULTI180. Broken parts will affect the MULTI180 operation. Replace or repair damaged or worn parts immediately.
- When MULTI180 is not in use, store it in a secure place out of the reach of children. Inspect it for good working condition prior to storage and before re-use.

## Caring for the Environment

When a tool is no longer usable it should not be disposed of with household waste, but in an environmentally friendly way. Please recycle where facilities exist. Check with your local council authority for recycling advice.

Recycling packaging reduces the need for landfill and raw materials. Reuse of recycled material decreases pollution in the environment. Please recycle packaging where facilities exist. Check with your local council authority for recycling advice.

## Transport and Storage

- Hold the handle or the bottom to move it.
- The machines should be firmly secured during transportation.
- The machines should be stored out of the rain.
- Keep notice of Attention sign on the packing box.

## DESCRIPTION

The MULTI180 series is a DC inverter MIG ARC TIG welder. This unit uses 1~Phase 240V, 50/60HZ AC power. A time delay fuse or circuit breaker is recommended. The MULTI180 series is ideal for Do-It-Yourself projects or for light maintenance. MIG/MAG weld carbon steel, stainless steel.



## Specifications and Dimensions

Item	MULTI180
Input power	240V (220 ~ 240)
Frequency	50/60Hz
Rated input current	31.5A
Rated input capacitance	8.7KVA
No-load voltage	71V
Rated working voltage	23V
MMA welding current	20 ~ 160A
LIFT Arc welding current	15 ~ 180A
MIG welding current	30 ~ 180A
Rated duty cycle	10%
Welding current (10min)	10%@100A
10min/100%	56.9A
Efficiency	56.9% $\eta$
Power factor	0.75 Cos $\phi$
Insulation class	H
Enclosure protection	21S IP
Cooling type	Fan cooled
Dimension	524x242x411(LxWxHmm)
Weight	14kg

## Unpacking

1. Remove cartons, bags or Styrofoam containing the welder and accessories.
2. Check the contents with the packing list below.

Item	QTY
DC Inverter Multi Welder	1 unit
3m MIG gun	1pc
3m Electrode holder	1pc
3m Cable with earth clamp	1pc
Gas hose $\phi$ 8mm	4m
Tip $\phi$ 0.6	1pc
Tip $\phi$ 0.8	1pc
Tip $\phi$ 0.9	1pc
Tip $\phi$ 1.0	1pc
V Roller 0.6-0.9mm	1pc
K Roller 0.8-1.0mm	1pc
Wrench	1pc
Operator's Manual	1

3. After unpacking unit, inspect carefully for any damage that may have occurred during transit. Check for loose, missing, or damaged parts. Shipping damage claim must be filed with carrier.

## Front Control Panel

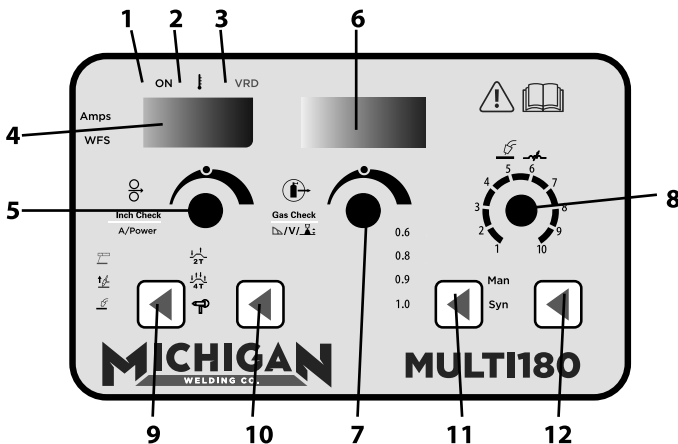

1. **Power Indicator:** When the machine is turned on, the power indicator will be on.
2. **Alarm Indicator:** When the thermal indicator is on, it shows the machine is overloaded and the internal temperature is too high. Weld output will turn off automatically but the fan will still be working. When the internal temperature is decreased, the overload light will turn off and the machine will be ready to weld.
3. **VRD Indicator:** When the VRD indicator is on, it means the welder's output voltage is safe ( $\leq 13V$ ), it will be off when the welder is working.
4. **Current Display Indicator:** Displays current setting, and shows actual current when the welder is working.
5. **Left Adjust Dial:** press the dial to toggle between Amps and WFS (Wire Feed Speed displayed in m/min), adjust both settings by turning the dial. When pressed and held down the 'inch check' function will activate which runs the wire feed motor to load the wire into the MIG Torch.
6. **Voltage Display Indicator:** It will be display Arc-Force preset in MMA mode, and display voltage preset in MIG mode, and display actual voltage when the welder is working.
7. **Middle Adjust Dial:** Its main function is adjusting Arc-Force in MMA mode, and adjusting welding voltage in MIG mode. Users can press down the knob in MIG to activate then gas-check function.
8. **MIG/Mag Electrical Inductor Adjust Knob:** Its main function is adjusting arc's inductance in MIG/MAG.
9. **Weld Function Selection Button:** Users can cycle through MMA LIFT Arc or MIG welding modes by pressing this button, and the indicators at the left part of button will indicate the selected welding process.
10. **2T/4T:** Users can select 2T or 4T gun trigger mode in MIG by pressing this button.
11. **Mig Wire Diameter Selection Button:** Users can select wire diameter.
12. **Mig/Mag Manual/Syn Selection Button:** Users can select manual or synergic mode by this button, and the indicators at the left part of button will indicate the selection mode. **Users need choose correct material and wire diameter first, so the actual welding current will be close to the preset current. User need find suitable welding parameters by themselves in manual mode. But in syn mode, the preset welding voltage will auto-adjust base on preset welding current or wire speed, and user can adjust arc length from -5.0V to +5.0V.**

# INSTALLATION

## Machine and gas setup

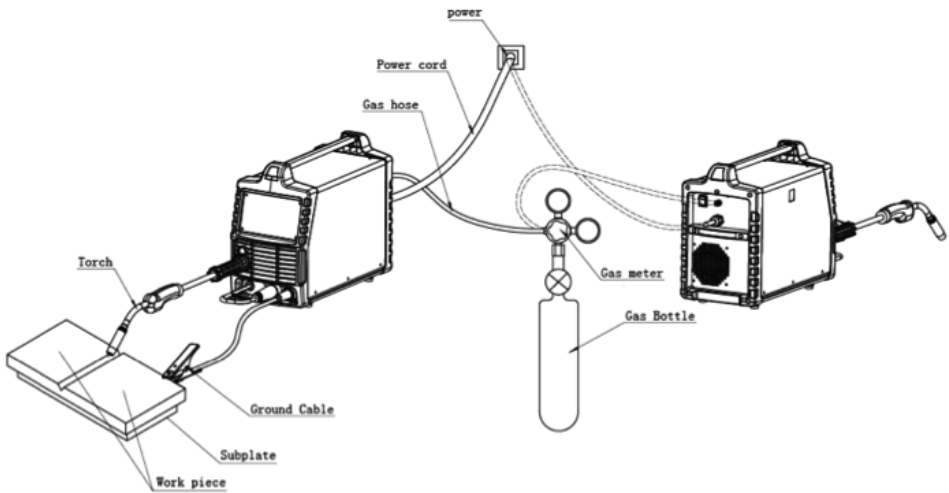

## Power Requirement

AC single phase 240V, 50/60 Hz fused with a suitable time delayed fuse or circuit breaker is required



### WARNING

High voltage danger from power source! Consult a qualified electrician for proper installation of receptacle. This welder must be grounded while in use to protect the operator from electrical shock.

Do not remove grounding prong or alter the plug in any way. Do not use any adapters between the welder's power cord and the power source receptacle. Make sure the POWER switch is OFF when connecting your welder's power cord to a properly grounded 240Vac, 50/60Hz, single phase power source.

## Extension Cord

It is strongly recommended that an extension cord should not be used because of the voltage drop they produce. This drop in voltage can affect the performance of the welder. If you need to use an extension cord it must be at least 6mm<sup>2</sup> and less than 8 min length.



# Setting Up The Work Piece

## Welding positions

There are two basic positions, for welding: Flat and Horizontal. Flat welding is generally easier, faster, and allows for better penetration. If possible, the work piece should be positioned so that the bead will run on a flat surface.

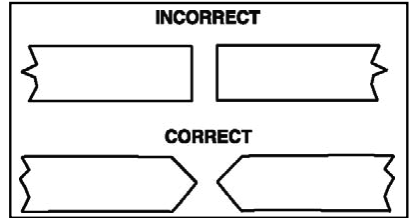

## Preparing the joint

Before welding, the surface of work piece needs to be free of dirt, rust, scale, oil or paint. Or it will create brittle and porous weld. If the base metal pieces to be joined are thick or heavy, it may be necessary to bevel the edges with a metal grinder. The correct bevel should be around 60 degrees.

## See following picture:

Based on different welding position, there are different welding joint, see following images for more information

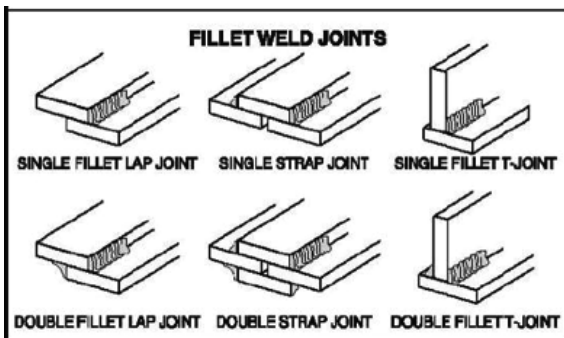
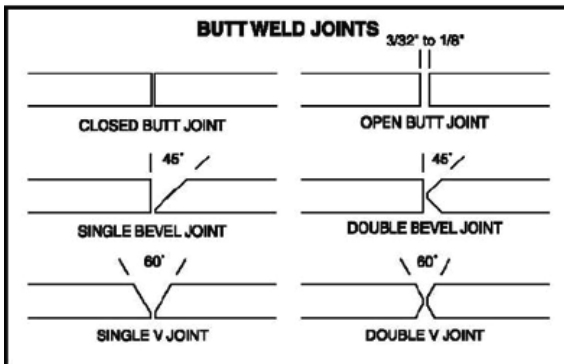

## Ground Clamp Connection

Connect the earth clamp cable to the negative terminal on the front of the machine, and the clamp to the work piece. Clear any dirt, rust, scale, oil or paint on the ground clamp. Make certain you have a good solid ground connection. Make sure the ground clamp touches the metal.

## Gas Installation

### 1. Settings of different wire welding ways.



#### WARNING

Shielding gas cylinders and high pressure cylinders can explode if damaged, so treat them carefully.

- Never expose cylinders to high heat, sparks, open flames, mechanical shocks or arcs.
- Do not touch cylinder with MIG gun.
- Do not weld on the cylinder.
- Always secure cylinder upright to a cart or stationary object.
- Keep cylinders away from welding or electrical circuits.
- Use the proper regulators, gas hose and fittings for the specific application.

When MIG (solid) wires are used, the shielding gas is required.

#### With Gas Shielded Welding Output Line-Connection (DCEP)

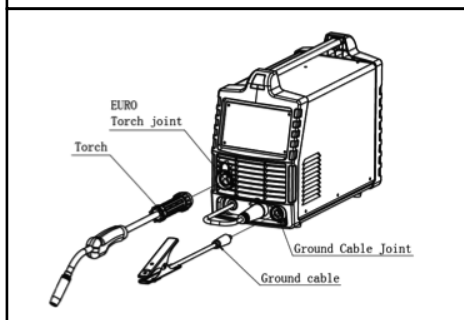

#### Without Gas Shield Welding (DCEN)

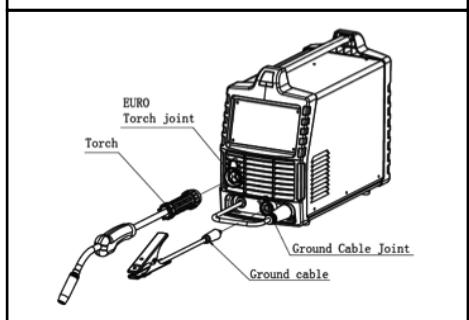

1. Change the welding mode to the MIG welding mode;
2. For gas welding use DCEP setup, with earth clamp plugged into the negative polarity socket.
3. For gasless welding use DCEN setup, with earth clamp plugged into the positive polarity socket. 2

## 2. The gas hose

The gas hose, regulator and gas cylinder connection. Attach one end of the gas hose to the gas solenoid valve (gas inlet) located on the back panel of the welder. Attach the other end to the gas regulator which is attached to the shielding gas cylinder. See illustration below:

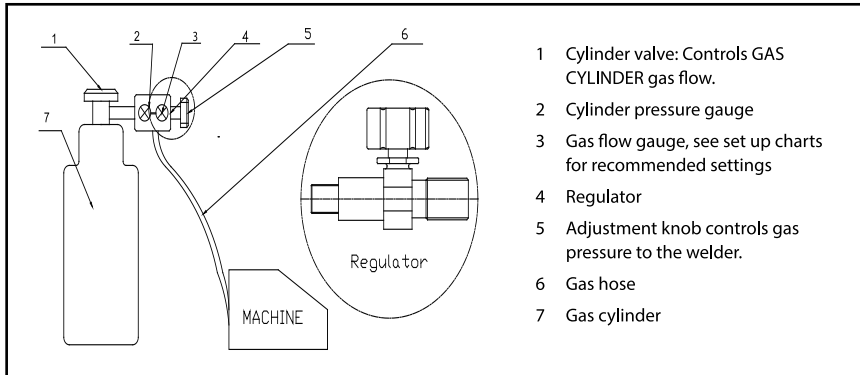

**NOTE:** Slowly open the cylinder valve by turning it counterclockwise until the cylinder pressure gauge registers on the first gauge of the regulator. Turn the adjustment knob clockwise (right) slowly to increase gas flow (check the set up guide on the machine for guidelines on gas flow. To reduce the gas flow, turn the adjustment counterclockwise (left). The gas valve is located on the back panel of the welder and activated by the trigger. Gas flow should be heard when the trigger is activated. Avoid unnecessary gas loss by closing the tank valve when finished welding.

## 3. Gas selection

Different materials require different shielding gas when MIG welding, refer to the set up chart inside the wire feed compartment.

### Materials – Shielding Gas Types

- **Mild steel:** Use Argon 5/2 for reduced spatter and reduced penetration for thinner materials.
- **Mild Steel:** Use CO2 for deeper penetration but increased spatter.
- **Stainless steel:** Use Argon 98% and CO2 2%
- **Aluminum or bronze:** Use 100% Argon

## Installation of wire spool

1. Open the door on the side of the machine, rotate the adjusting nut on the wire shaft anti-clockwise to remove it from the wire spool screw, and then remove the wire spool block seat;
2. Install the wire spool on the screw, fit the block seat and tighten up the adjusting nut. Ensure the wire spool moves freely.

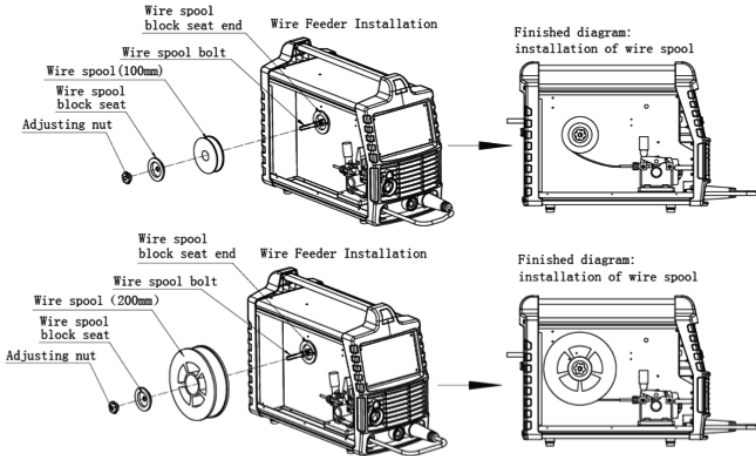

## Installation of the Wire Feeder and the Right Connection of the Wire

1. While installing the wire spool, check the contact tip that is installed on the MIG torch and the roller installed on the wire feed motor is of the correct diameter.
2. Open the wire feed motor by moving back the adjusting rod to release the tensioner.
3. Insert the wire to the wire feeder through the wire tube and turn the wire spool to feed through the wire feeder until it comes through to the EURO torch socket by around 50mm.
4. Reinstall the tensioner and adjust the tension.
5. Install the MIG torch and press/hold down dial 5 to feed the wire through to the end of the MIG torch.

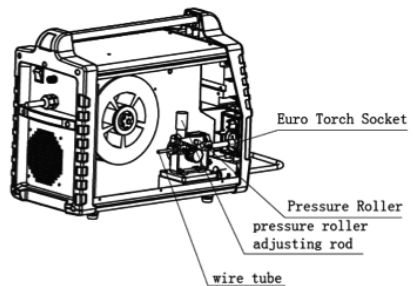

## Setting The Welding Parameters



### WARNING

Arc flash can injure eyes! To reduce the risk of arc flash, make certain that the wire coming out of the end of the torch does not come in contact with work piece, ground clamp or any grounded material during the drive tension setting process or arcing will occur.

### Manual Mode

1. Press the trigger on the torch.
2. Turn the drive tension adjustment knob clockwise, increasing the drive tension until the wire seems to feed smoothly without slipping.

### Syn Mode

1. Select correct wire and diameter material; then preset suitable welding currents and arc length (0 is recommended).
2. Press the trigger on the torch for welding.

## Replacement of Roller

1. Open the door of the machine shell. Please remove the wire first if there is still wire on the wire feeder;
2. Release tension from the wire feed motor;
3. Grab the wire feed roller with hands to pull it out slightly, then un-install the needed wire feeder and wire feeding roller from the shaft;

**Note:** Do not use a hammer to install the roller.

4. After the installation of wire roller, screw the cover clockwise tightly. Make sure the screw thread connection is correct, to avoid damaging of the screw thread due to the connection deviation.

**Remark:** The spec's marked on the front of the roller is the size of roller groove in the back of the roller, i.e the size of the roller in use.

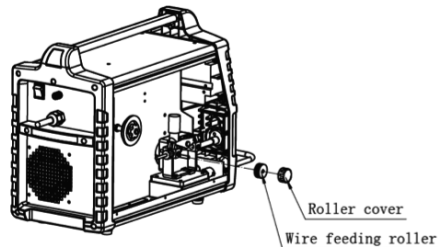

# MIG GMAW OPERATION



## WARNING

**HIGH VOLTAGE DANGER FROM POWER SOURCE!** Consult a qualified electrician for proper installation of receptacle at the power source.

This welder must be grounded while in use to protect the operator from electrical shock. If you are not sure if your outlet is properly grounded, have it checked by a qualified electrician.

Do not cut off the grounding clamp or alter the plug in any way and do not use any adapters between the welder's power cord and the power source receptacle. Make sure the POWER switch is OFF before connecting your welder's power cord to a properly grounded 240VAC(220v-240v), 50/60Hz, single phase power source.

## Main control component

- a) **Power switch** - The power switch supplies electrical current to the welder. Whenever the power switch is in the ON position, the welding circuit is activated. ALWAYS turn the power switch to the OFF position and unplug the welder before performing any maintenance.
- b) **Voltage selector** - The voltage selector controls the welding heat. This unit has infinite voltage control. Refer to the label inside the welder side door for recommended voltage selector settings for your welding job.
- c) **Wire speed control (current preset in synergic mode)** - The wire speed control adjusts the speed at which the wire is fed out of the welding torch. The wire speed needs to be closely matched (tuned-in) to the rate at which it is being melted off. Some things that affect wire speed selection are the type and diameter of the wire being used, the heat setting selected, and the welding position to be used.  
**Note:** *The wire will feed faster without an arc. When an arc is being drawn, the wire speed will slow down.*

## Holding the torch

The best way to hold the welding torch is the way that feels most comfortable to you and ensures the torch nozzle is at a correct angle. While practicing to use your new welder, experiment holding the torch in different positions until you find the one that seems to work best for you.

## Position the torch to the work piece

There are two angles of the torch nozzle in relation to the work piece that must be considered when welding.

ANGLE A: Can be varied, but in most cases the optimum angle will be 60 degrees, the point at which the torch handle is parallel to the work piece. If angle A is increased, penetration will increase. If angle A is decreased, penetration will decrease also.

ANGLE B: Can be varied for two reasons: to improve the ability to see the arc in relation to the weld puddle and to direct the force of the arc.

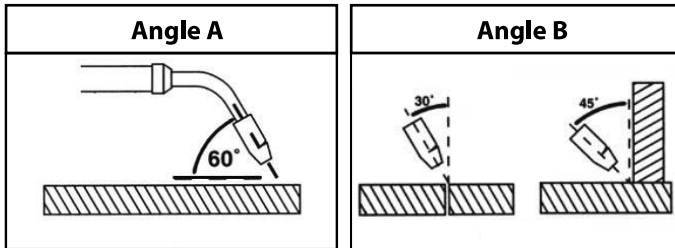

### Distance from the work piece

If the nozzle is held off the work piece, the distance between the nozzle and the work piece should be kept constant and should not exceed 6.4mm or the arc may begin sputtering, signalling a loss in welding performance.

### Fine tuning the wire speed

This is one of the most important parts of MIG welder operation and must be done before starting each welding job or whenever any of the following variables are changed: heat setting, wire diameter, or wire type.

1. Connect the Ground Clamp to a scrap piece of the same type of material which you will be welding. It should be equal to or greater than the thickness of the actual work piece, and free of oil, paint, rust, etc.
2. Select a heat setting.
3. Hold the torch in one hand, allowing the nozzle to rest on the edge of the work piece farthest away from you, and at an angle similar to that which will be used when welding. (See HOLD THE TORCH if you are uncertain of the angle at which you will be welding).
4. With your free hand, turn the Wire Speed Dial to maximum and continue to hold onto the knob.
5. Lower your welding helmet and pull the trigger on the torch to start an arc, then begin to drag the torch toward you while simultaneously turning the Wire Speed Dial counter-clockwise.

As you decrease the wire speed, the sound that the arc makes will change from a sputtering to a high-pitched buzzing sound and then will begin sputtering again if you decrease the wire speed too much. The point on the wire speed adjustment where the high-pitched buzzing sound is achieved is the correct setting. You can use the wire speed control to slightly increase or decrease the heat and penetration for a given heat setting

by selecting higher or lower wire speed settings. Repeat this tune-in procedure if you select a new heat setting, a different diameter wire, or a different type of welding wire.

## Welding Techniques

**EXPOSURE TO A WELDING ARC IS EXTREMELY HARMFUL TO THE EYES AND SKIN!**



### **WARNING**

Prolonged exposure to the welding arc can cause blindness and burns. Never strike an arc or begin welding until you are adequately protected. Wear flame proof welding gloves, a heavy long sleeved shirt, trousers without cuffs, high topped shoes and an AS/NZS 1338.1.1992 SAFETY STANDARD approved welding helmet.

**ELECTRIC SHOCK CAN KILL!** To prevent **ELECTRIC SHOCK**, do not perform any welding while standing, kneeling, or lying directly on the grounded work.

### **Moving the torch**

Torch travel refers to the movement of the torch along the weld joint and is broken into two elements: Direction and Speed. A solid weld bead requires that the welding torch be moved steadily and at the right speed along the weld joint. Moving the torch too fast, too slow, or erratically will prevent proper fusion or create a lumpy, uneven bead.

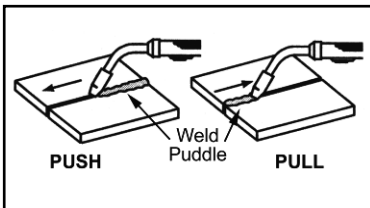

**TRAVEL DIRECTION** is the direction the torch is moved along the weld joint in relation to the weld puddle. The torch is either **PUSHED** into the weld puddle or **PULLED** away from the weld puddle.

For most welding jobs you will pull the torch along the weld joint to take advantage of the greater weld puddle visibility.

**TRAVEL SPEED** is the rate at which the torch is being pushed or pulled along the weld joint. For a fixed heat setting, the faster the travel speed, the lower the



penetration and the lower and narrower the finished weld bead. Likewise, the slower the travel speed, the deeper the penetration and the higher and wider the finished weld bead.

### Types of welding beads

As you become more familiar with your new welder and better at laying some simple weld beads, you can begin to try some different weld bead types.

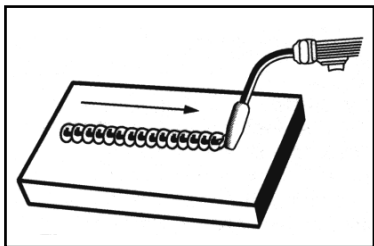

The **STRINGER BEAD** is formed by traveling with the torch in a straight line while keeping the wire and nozzle centred over the weld joint (See image above)

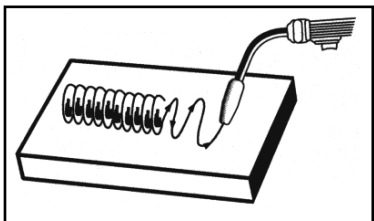

The **WEAVE BEAD** is used when you want to deposit metal over a wider space than would be possible with a stringer bead. It is made by weaving from side to side while moving with the torch. It is best to hesitate momentarily at each side before weaving back the other way.

### Welding position

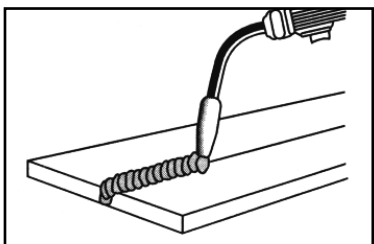

**FLAT POSITION** is the easiest of the welding positions and is most commonly used. It is best if you can weld in the flat position if at all possible as good results are easier to achieve.

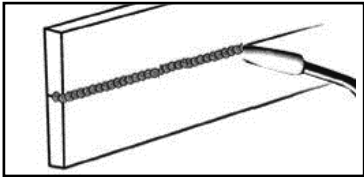

**HORIZONTAL POSITION** is performed very much the same as the flat weld except that angle B (see HOLDING THE TORCH) is such that the wire, directed more toward the metal above the weld joint is to help prevent the weld puddle from running downward while still allowing slow enough travel speed. A good starting point for angle B is about 30 degrees DOWN from being perpendicular to the work piece.

**VERTICAL POSITION** is easier for many people to Pull the torch from top to bottom. It can be difficult to prevent the puddle from running downward. Pushing the torch from bottom to top may provide better puddle control and allow slower rates of travel speed to achieve deeper penetration. When vertical welding, angle B (see HOLDING THE TORCH) is usually always kept at zero, but angle A will generally range from 45 to 60 degrees to provide better puddle control.

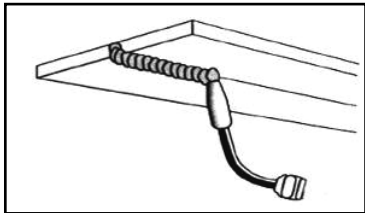

**OVERHEAD POSITION** Is the most difficult welding position. Angle A (see HOLDING THE TORCH) should be maintained at 60 degrees. Maintaining this angle will reduce the chances of molten metal falling into the nozzle. Angle B should be held at zero degrees so that the wire is aiming directly into the weld joint. If you experience excessive dripping of the weld puddle, select a lower heat setting. Also, the weave bead tends to work better than the stringer.

## Multiple pass welding

**BUTT WELD JOINTS** when butt welding thicker materials you will need to prepare the edges of the material to be joined by grinding a bevel on the edge of one or both pieces of the metal being joined. When this is done, a "V" is created between the two pieces of metal that will have to be welded closed. In most cases more than one pass or bead will need to be laid into the joint to close the "V".

Laying more than one bead into the same weld joint is known as a multiple-pass weld.

The illustrations in following figure show the sequence for laying multiple pass beads into a single "V" butt joint.

**Note:** When using self-shielding flux-core wire it is very important to thoroughly chip and brush the slag off each completed weld bead before making another pass or the next pass will be of poor quality.

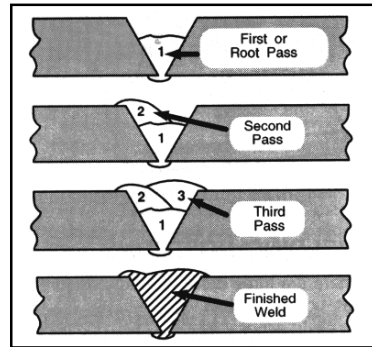

**FILLET WELD JOINTS** Most fillet weld joints, on metals of moderate to heavy thickness, will require multiple pass welds to produce strong joint. The illustration below show the sequence of laying multiple pass beads into a T fillet joint and a lap fillet joint.

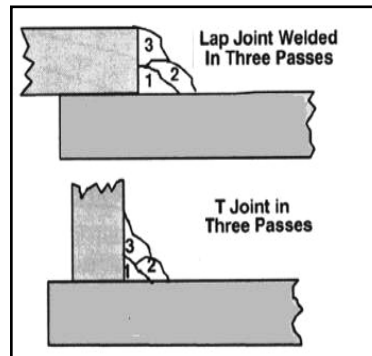

## Spot welding

There are three methods of spot welding: Burn-Through, Punch and Fill, and Lap. Each has advantages and disadvantages depending on the specific application as well as personal preference.

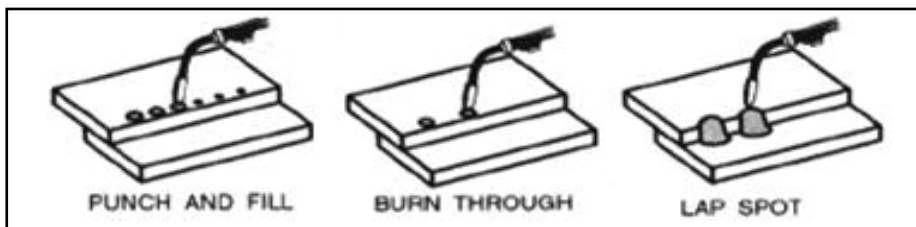

**PUNCH AND FILL METHOD** produces a weld with the most finished appearance of the three spot weld methods. In this method, a hole is punched or drilled into the top piece of metal and the arc is directed through the hole to penetrate into the bottom piece. The puddle is allowed to fill up the hole leaving a spot weld that is smooth and flush with the surface of the top piece. Select the wire diameter, heat setting, and tune in the wire speed as if you were welding the same thickness material with a continuous bead.

**BURN-THROUGH METHOD** welds two overlapped pieces of metal together by burning through the top piece and into the bottom piece. With the burn-through method, larger wire diameters tend to work better than smaller diameters. Wire diameters that tend to work best, with the burn-through method are 0.035 inch self-shielding flux-core wire. Do not use .030 inch self-shielding flux core wires when using the burn-through method unless the metal is VERY thin or excessive filler metal build-up and minimal penetration is acceptable. Always select the HIGH heat setting with the burn-through method and tune in the wire speed prior to making a spot weld.

**LAP SPOT METHOD** directs the welding arc to penetrate the bottom and top pieces, at the same time, right along each side of the lap joint seam. Select the wire diameter, heat setting, and tune in the wire speed as if you were welding the same thickness material with a continuous bead.

### **Spot welding instructions**

1. Select the wire diameter and heat setting recommended above for the method of spot welding you intend to use.
2. Tune in the wire speed as if you were going to make a continuous weld.
3. Hold the nozzle piece completely perpendicular to and about 1/4 inch off the work piece.
4. Pull the trigger on the torch and release it when it appears that the desired penetration has been achieved.
5. Make practice spot welds on scrap metal, varying the length of time you hold the trigger, until a desired spot weld is made.
6. Make spot welds on the actual work piece at desired locations.

# ARC MMA OPERATION

## Electrode

The welding electrode is a rod coated with a layer of flux. When welding, electrical current flows between the electrode (rod) and the grounded metal work piece. The intense heat of the arc between the rod and the grounded metal melts the electrode and the flux. The most popular electrodes are:

- E6011 60,000 PSI tensile strength deep penetrating applications.
- E6013 60,000 PSI tensile strength used for poor fit up applications
- E7014 70,000 PSI tensile strength used for high deposition and fast travel speeds with light penetration
- E7018 70,000 PSI tensile strength, used for out of position and tacking.

## Selecting The Proper Amperage For The Electrode

There is no golden rule that determine the exact rod or heat setting required for every situation. The type and thickness of metal and the position of the work piece determine the electrode type and the amount of heat needed in the welding process. Heavier and thicker metals required more amperage.

### Electrode/Amperage Guide

2.5mm diameter E6013 Electrodes – 60 to 100amps

3.2mm diameter E6013 Electrodes – 80 to 150amps

It is best to practice your welds on scrap metal which matches the metal you intend to work with to determine correct heat setting and electrode choice. See the following trouble shooting tips to determine if you are using a correct electrode.

1. When proper rod is used:
  - a) The bead will lay smoothly over the work without ragged edges
  - b) The base metal puddle will be as deep as the bead that rises above it
  - c) The welding operation will make a crackling sound similar to the sound of bacon frying
2. When a rod too small is used
  - a) The bead will be high and irregular
  - b) The arc will be difficult to maintain

3. When the rod is too large
  - a) The arc will burn through light metals
  - b) The bead will undercut the work
  - c) The bead will be flat and porous
  - d) Rod may be freeze or stick to work piece

**Note:** Rate of travel over the work also affects the weld. To ensure proper penetration and enough deposit of rod, the arc must be moved slowly and evenly along the weld seam.

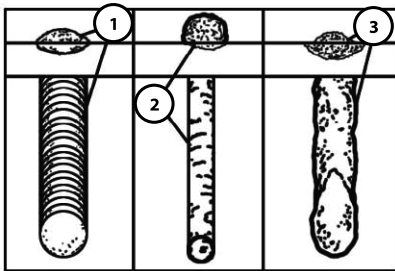

### Electrode holder connection

1. Attach the Twist-lock electrode holder to the +ve terminal on the MULTI180
2. Open the electrode holder by turning the head and handle in the opposite directions until the head clamp opens.
3. Place the exposed end of the electrode into the lead clamp and hold in place.
4. Turn the handle to close the head clamp.

### Setting the amperage control

The welder has an infinite output current control.

There is no golden rule that determines the exact amperage required for every situation. It is best to practice your welds on scrap metal which matches the metals you intend to work with to determine correct setting for your job. The electrode type and the thickness of the work piece metal determine the amount of heat needed in the welding process. Heavier and thicker metals require more voltage (amperage), whereas lighter and thinner metals require less voltage (amperage).

### Electrode/Amperage Guide

- 2.5mm diameter E6013 Electrodes – 60 to 100amps
- 3.2mm diameter E6013 Electrodes – 80 to 150amps

## Welding techniques

The best way to teach yourself how to weld is with short periods of practice at regular intervals. All practice welds should be done on scrap metal that can be discarded. Do not attempt to make any repairs on valuable equipment until you have satisfied yourself that your practice welds are of good appearance and free of slag or gas inclusions.

### Holding the electrode

The best way to grip the electrode holder is the way that feels most comfortable to you. To Position the Electrode to the work piece when striking the initial arc, it may be necessary to hold the electrode perpendicular to the work piece. Once the arc is started the angle of the electrode in relation to the work piece should be between 10 and 30 degrees. This will allow for good penetration, with minimal spatter.

### Striking the arc



#### **WARNING**

**EXPOSURE TO A WELDING ARC IS EXTREMELY HARMFUL TO THE EYES AND SKIN.**

Never strike an arc or begin welding until you have adequate protection. Wear flame proof welding gloves, heavy long-sleeved shirt, trousers without turn-ups, safety shoes and a welding helmet or face mask.

Scratch the work piece with the end of electrode to start arc and then raise it quickly about 0.32cm gap between the rod and the work piece. See picture (right).

It is important that the gap be maintained during the welding process and it should be neither too wide or too narrow. If too narrow, the rod will stick to the work piece. If too wide, the arc will be extinguished. It needs much practice to maintain the gap. Beginners may usually get sticking or arc extinguishing. When the rod sticks to the work piece, gently rock it back and forth to make them separate. If not, the circuit is short connection, and it will overload the welder. A good arc is accompanied by a crisp, cracking sound. The sound is similar to that made by eggs frying. To lay a weld bead, only 2 movements are required; downward and in the direction the weld is to be laid, as in following figure:

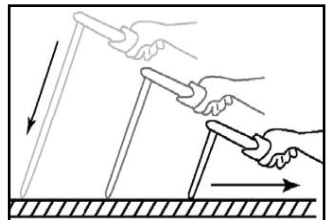
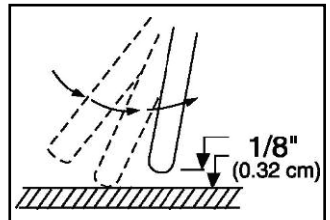

## Types of weld bead

The following paragraphs discuss the most commonly used arc welding beads.

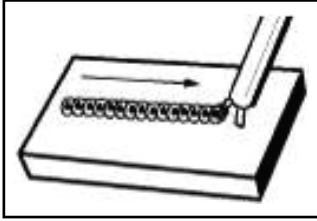

The **STRINGER BEAD** is formed by traveling with the electrode in a straight line while keeping it centred over the weld joint.

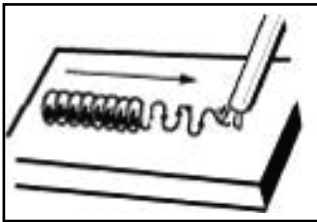

The **WEAVE BEAD** is used when you want to deposit metal over a wider space than would be possible with a stringer bead. It is made by weaving from side to side while moving with the electrode. It is best to hesitate momentarily at each side before weaving back the other way to improve penetration.

## Welding position

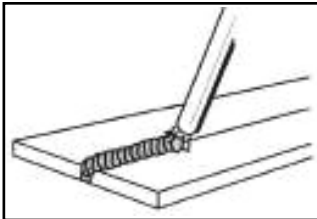

**FLAT POSITION** is the easiest of the welding positions and is most commonly used. It is best if you can weld in the flat position if at all possible as good results are easier to achieve.

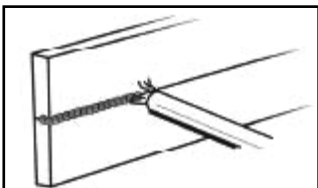



The **HORIZONTAL POSITIONS** are performed very much the same as the flat weld except that the angle is different such that the electrode, and therefore the arc force, is directed more toward the metal above the weld joint. This more direct angle helps prevent the weld puddle from running downward while still allowing slow enough travel speed to achieve good penetration. A good starting point for your electrode angle is about 30 degrees DOWN from being perpendicular to the work piece.

### How to judge a good weld bead

When the trick of establishing and holding an arc has been perfected, the next step is learning how to run a good bead. The first attempts in practice will probably fall short of acceptable weld beads. Too long of an arc will be held or the travel speed will vary from slow to fast (see following):

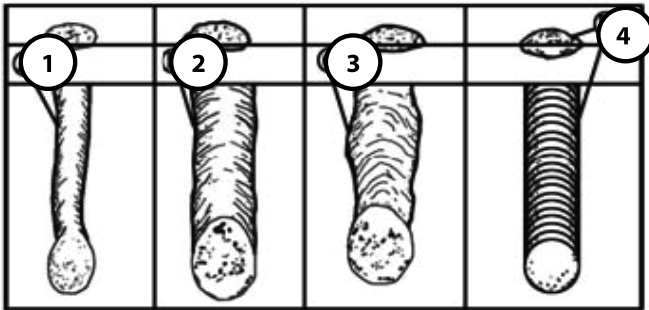

1. Weld speed is too fast.
2. Weld speed is too slow.
3. Arc is too long.
4. Ideal weld.

A solid weld bead requires that the electrode be moved slowly and steadily along the weld seam. Moving the electrode rapidly or erratically will prevent proper fusion or create a lumpy, uneven bead. To prevent **ELECTRIC SHOCK**, do not perform any welding while standing, kneeling, or lying directly on the grounded work.

### How to finish the bead

As the coating on the outside of the electrode burns off, it forms an envelope of protective gasses around the weld. This prevents air from reaching the molten metal and creating an undesirable chemical reaction. The burning coating, however, forms slag. The slag formation appears as an accumulation of dirty metal scale on the finished weld. Slag should be removed by striking the weld with a chipping hammer.

# TIG GTAW OPERATION

When connecting torches, ensure the machine is off and the supply cable is unplugged.

TIG welding is done in DC EN set up. The ground/earth cable connects to the positive (+) terminal. The torch cable connects to the positive terminal.

TIG welding requires an ARGON gas supply. Connect the gas hose from the LTIG torch to a regulator affixed to an ARGON gas supply.

Ensure the correct tungsten (check for dia and type) is installed on the LTIG torch and set up correctly.

## Installation

Depending on the application, the correct collet, collet body, gas cup, electrode and electrode tip configuration should be fitted (See tables on next page)

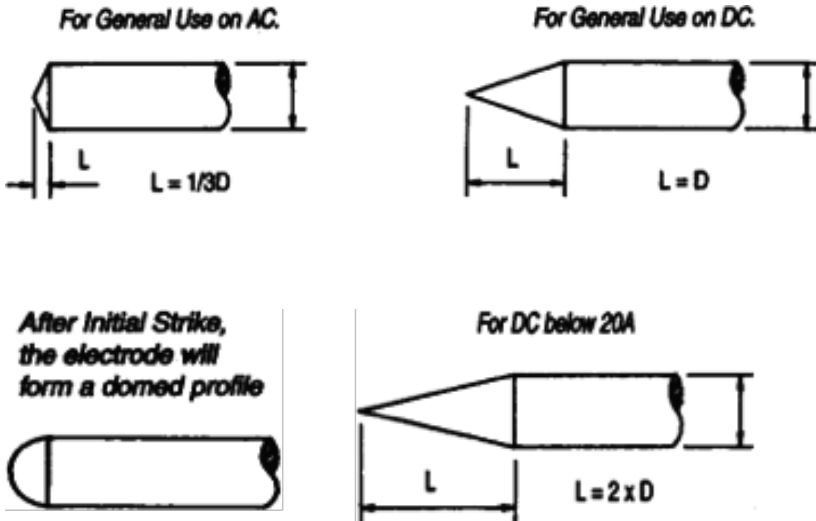

You are now ready to connect the torch to the power source and gas supply. Once connected check you have adequate gas flow.

## Operation

Once the installation guidelines have been followed you are ready to weld.

When using the torch do not exceed its published current carrying capacity and duty cycle rating.

## Duty Cycle

The duty cycle of a torch expresses the maximum time a torch can deliver its rated output during a test period without exceeding the temperature limits of its components.

Ratings are generally based on a 10-minute cycle. Therefore a 60% duty cycle implies a 6-minute weld period followed by a 4-minute break. A 100% duty cycle is equal to continuous welding.

	DC							
Electrode Diameter (mm)	0.5	1.0	1.6	2.4	3.2	4.0	4.8	6.4
<b>Maximum Welding Current (Amps)</b>								
Thoriated Electrode	20	60	70	120	200	300	370	500
Zirconiated Electrode	N/A	N/A	N/A	N/A	N/A	N/A	N/A	N/A
Ceriated/Lanthanum/Electrode	N/A	60	70	120	200	300	370	500
<b>Ceramic Nozzle Bore Size (mm)</b>								
Thoriated Electrode	6	6	6	10	11	13	13	18
Zirconiated Electrode	8	8	8	11	13	18	18	N/A
Ceriated/Lanthanum Electrode	N/A	N/A	10	13	18	N/A	N/A	N/A

	AC							
Electrode Diameter (mm)	0.5	1.0	1.6	2.4	3.2	4.0	4.8	6.4
<b>Maximum Welding Current (Amps)</b>								
Thoriated Electrode	15	25	50	80	120	160	200	320
Zirconiated Electrode	15	25	50	80	120	160	200	320
Ceriated/Lanthanum/Electrode	N/A	25	50	80	120	160	200	320
<b>Ceramic Nozzle Bore Size (mm)</b>								
Thoriated Electrode	6	6	6	10	13	13	113	18
Zirconiated Electrode	8	8	8	11	13	18	18	N/A
Ceriated/Lanthanum Electrode	N/A	N/A	10	N/A	18	N/A	N/A	N/A

## Electrode Stick Out

Generally the electrode should not 'stick out' more than 10mm from the welding nozzle.

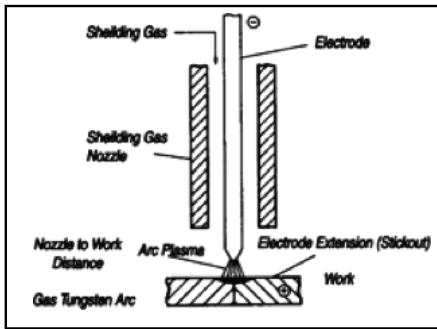

When an extended arc length is required or to reduce the risk of atmospheric weld defects due to poor shielding, a gas lens collet body should be used.

### Gas Lens bodies offer advantages of:

- Smooth columnar gas flow reducing the risk of atmospheric gas entrainment
- Reduced risk of weld defects in drafty conditions
- Longer arc lengths to improve visibility
- Slightly increased levels of performance and reduced gas consumption

### Laminar flow with Normal and Gas Lens Consumables

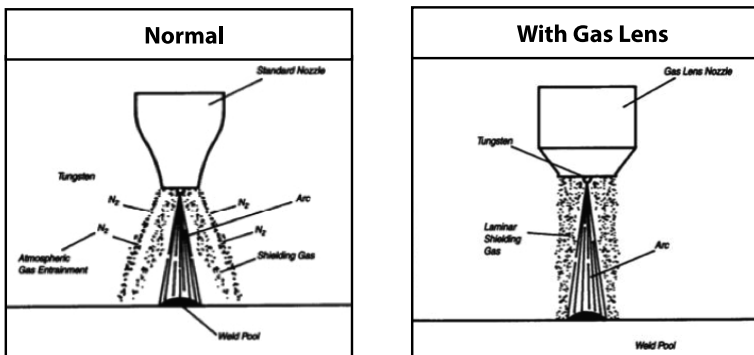

If any operational problems occur consult the trouble- shooting guide.

## TIG MAINTENANCE, SERVICE TIPS AND ADVICE

- Periodically remove the nozzle, head insulators, collet and collet body and inspect for wear and damage. Any worn or damaged parts should be changed immediately.
- Care should be taken not to let torch leads contact any hot surfaces. When the torch is not in use for prolonged periods ensure the high frequency switch is off.
- If the torch has not been used for 15 minutes or more purge the gas line.
- Always ensure adequate gas and water flow prior to welding.
- To prevent electrode oxidation and aid electrode cooling an adequate post flow is recommended.
- The inclusion of a torch coolant containing corrosive retardants in the water supply is strongly recommended.

Cleanliness of both the weld joining areas and filler metals are an important consideration in the TIG process. Oil, grease, dust, paint or marking crayon and corrosion deposits must be removed from the immediate joint area.

- The chief causes of arc instability and contaminated welds are;
- Contact of electrode tip with molten weld pool
- Contamination of electrode tip by weld pool spatter
- Contact of filler metal with electrode tip
- Exceeding the current carrying capacity of a given electrode size
- The extension of an electrode beyond the recommended distance from the collet
- Inadequate tightening of collets and back caps
- Inadequate shielding flow or excessive drafts
- Electrode arc wander or defect in the electrode surface
- The use of improper shielding gas

## Trouble Shooting Guide for Gas Tungsten Arc Welding

Problem	Analysis	Solutions
Excessive Electrode Consumption	<ol style="list-style-type: none"> <li>1. Inadequate gas flow</li> <li>2. Operating on reverse polarity</li> <li>3. Improper size electrode for current required</li> <li>4. Excessive heating in holder</li> <li>5. Contaminated electrode</li> <li>6. Electrode oxidation during cooling</li> <li>7. Using gas containing oxygen or CO<sup>2</sup></li> </ol>	<ol style="list-style-type: none"> <li>1. Increase gas flow</li> <li>2. Use large electrode or change to straight polarity</li> <li>3. Use larger electrodes</li> <li>4. Check for proper collet contact</li> <li>5. Remove contaminated portion. Erratic results will continue as long as contamination exists</li> <li>6. Keep gas flowing after stopping arc for at least 10 – 15 seconds</li> <li>7. Change to proper gas</li> </ol>
Erratic arc	<ol style="list-style-type: none"> <li>1. Base metal is dirty or greasy</li> <li>2. Joint too narrow</li> <li>3. Electrode is contaminated</li> <li>4. Arc too long</li> </ol>	<ol style="list-style-type: none"> <li>1. Use appropriate chemical cleaners, wire brush or abrasives</li> <li>2. Open joint groove, bring electrode closer to work, decrease voltage</li> <li>3. Remove contaminated portion of electrode</li> <li>4. Bring holder closer to work to shorten arc</li> </ol>
Porosity	<ol style="list-style-type: none"> <li>1. Entrapped gas impurities (hydrogen, nitrogen, air, water, vapour)</li> <li>2. Defective gas hose or loose hose connections</li> <li>3. Oil film on base metal</li> </ol>	<ol style="list-style-type: none"> <li>1. Blow out air from all lines before striking arc. Use welding grade (99.99%) inert gas</li> <li>2. Check hose and connections for leaks</li> <li>3. Bring holder closer to work to shorten arc</li> </ol>
Tungsten contamination of work piece	<ol style="list-style-type: none"> <li>1. Contact starting with electrode</li> <li>2. Electrode melting and alloying with base metal</li> <li>3. Touching tungsten metal pool</li> </ol>	<ol style="list-style-type: none"> <li>1. Using high frequency start or using copper striker plate</li> <li>2. Use less current or larger electrode</li> <li>3. Keep tungsten out of molten pool</li> </ol>

Problem	Analysis	Solutions
Excessive ceramic cup usage	<ol style="list-style-type: none"> <li>1. Excess duty of cycle torch</li> <li>2. Too small a nozzle bore for size of tungsten</li> <li>3. Thermal shock</li> </ol>	<ol style="list-style-type: none"> <li>1. Change torch</li> <li>2. Increase bore of nozzle</li> <li>3. Increase bore of nozzle or warm ceramic cup slowly from cold</li> </ol>

**Striking the arc method following step:**

1. Open the gas valve on the LTIG torch.
2. Tilt the torch at an angle, resting the alumina cup on the work piece,

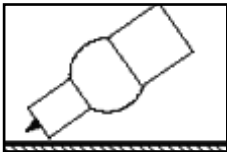

3. Rotate the torch to a vertical position, as you do so the tungsten should make contact with the work piece and start the arc.

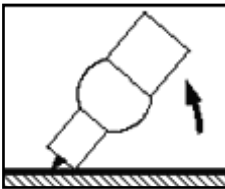

4. As soon as the arc is formed lift the torch from the work piece, by 2-3mm, to prevent the tungsten from sticking to the work and contamination of the tungsten.

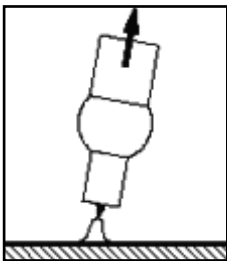

# SERVICE, MAINTENANCE, TRANSPORTATION & STORAGE

The welder needs regular maintenance as following:

- Periodically clean dust, dirt, grease, etc. from your welder.
- Every six months, or as necessary, remove the cover panel from the welder and air-blow any dust and dirt that may have accumulated inside the welder.
- Replace power cord, ground cable, ground clamp, or electrode assembly when damaged or worn.
- Store in a clean dry facility free from corrosive gas, excess dust and high humidity. Temperature range from 10°F-120°F and the relative humidity not more than 90%.
- When transporting or storing the welder after use, it is recommended to repack the product as it was received for protection. (Cleaning is required before storage and you must seal the plastic bag in the box for storage).

## Maintenance and Service

- The MULTI180 welder is a semi-automatic gas shielded welder. To properly operate & maintain the welder can assure it of good performance and prolong its operating life. Only the qualified personnel are allowed to be in charge of repairing. It is strongly recommended customers contact with our company or agent for technical, repairing, accessories supply and service back-up when they feel unable to work out the technical hitch or problems.
- Maintenance job should be conducted by an authorised service agent.
- The newly installed welder or it not in use for some time needs to be surveyed the insulation resistances between each winding and every winding to case with multimeter, which can not be less than 2.5MΩ.
- Keep from rain, snow and long term exposing to sunlight when welder is used outdoor.
- If the welder is not in use either for a long time or temporarily, it should be kept dry and have good ventilation to free it from moisture, eroded or toxic gas. The tolerable temperature ranges from -20°C+55°C, and the relative humidity can not be more than 90%.
- Dust removal
- The professional maintenance personnel should use dry compressed air (use air compressor or bellows) to remove the dust inside the machine. The part adhering to grease must be cleaned with cloth while make sure there are no loosing parts existed in the tightened places and connected cable. Usually the machine should be cleaned once a year if the dust accumulation problem is not very serious, while it needs cleaning once or even twice every quarter if the dust accumulation problem is serious.
- Regularly check the input & output cables of welder to guarantee they are firmly connected.
- Regularly check the gas system, for any abnormal sound and for any loose components.
- Keep torch cable direct when welding.



- Regularly clean the nozzle (do not knock the torch head to remove debris. Don't remove the feeder device by pulling the torch cable.
- Use welding specific wire, not inferior or rusty wire.

Replace the feed roll if it is showing wear and tear to prevent wire from feeding unevenly.



## **ATTENTION**

- The welder voltage is high, so the safety precautions should be implemented before repairing to avoid accidental shock. Under no circumstance can anyone except authorised service agents should open the case of the machine.
- Switch off the power source each time when removing dust.

No touching inside cable or work piece while removing dust. While practicing to use your new welder, experiment holding the torch in different positions until you find the one that seems to work best for you.

# MULTI180 TROUBLE SHOOTING CHART

No	Breakdown	Analysis	Solutions
1	Yellow Indicator is on	Voltage is too high ( $\geq 15\%$ )	Switch off power source; Check the main supply; Restart welder when power recovers to normal state.
		Voltage is too low ( $\leq 15\%$ )	
		Bad power ventilation lead to over-heat protection	Improve the ventilation condition.
		Circumstance temperature is too high.	It will automatically recover when the temperature low down.
		Using over the rated duty-cycle.	It will automatically recover when the temperature low down.
2	Wire feeding motor don't work	Potentiometer not in the proper status	Change potentiometer
		Nozzle is blocked up	Change nozzle
		Feed roller is loose	Tighten the bolts
3	Cooling Fan not working or turning very slowly	Switch broken	Replace the switch
		Fan broken	Replace or repair the fan
		Wire broken or falling off	Check the connection
4	Arc is not stable and splash is large	Too large contact tip makes the current unsteady	Change the proper contact tip or roller
		Too thin power cable makes the power asceticism	Change the power cable
		Too low input voltage	Enhance the input voltage
		Wire feeding resistance is too large	Clean or replace the liner and the torch cable had better in the line direction.
5	Arc can't be pilot	Earth cable break	Connect earth cable
		Work piece has much greasy dirty or rusty stain	Clean greasy dirty or rusty stain
6	No shielded gas	Torch is not connected well	Connect the torch again
		Gas pipe is pressed or blocked up	Check gas system
		Gas system rubber pipe break	Connect gas system and bind firmly
7	Others		Please connect with our company

# MAIN CIRCUIT CHART

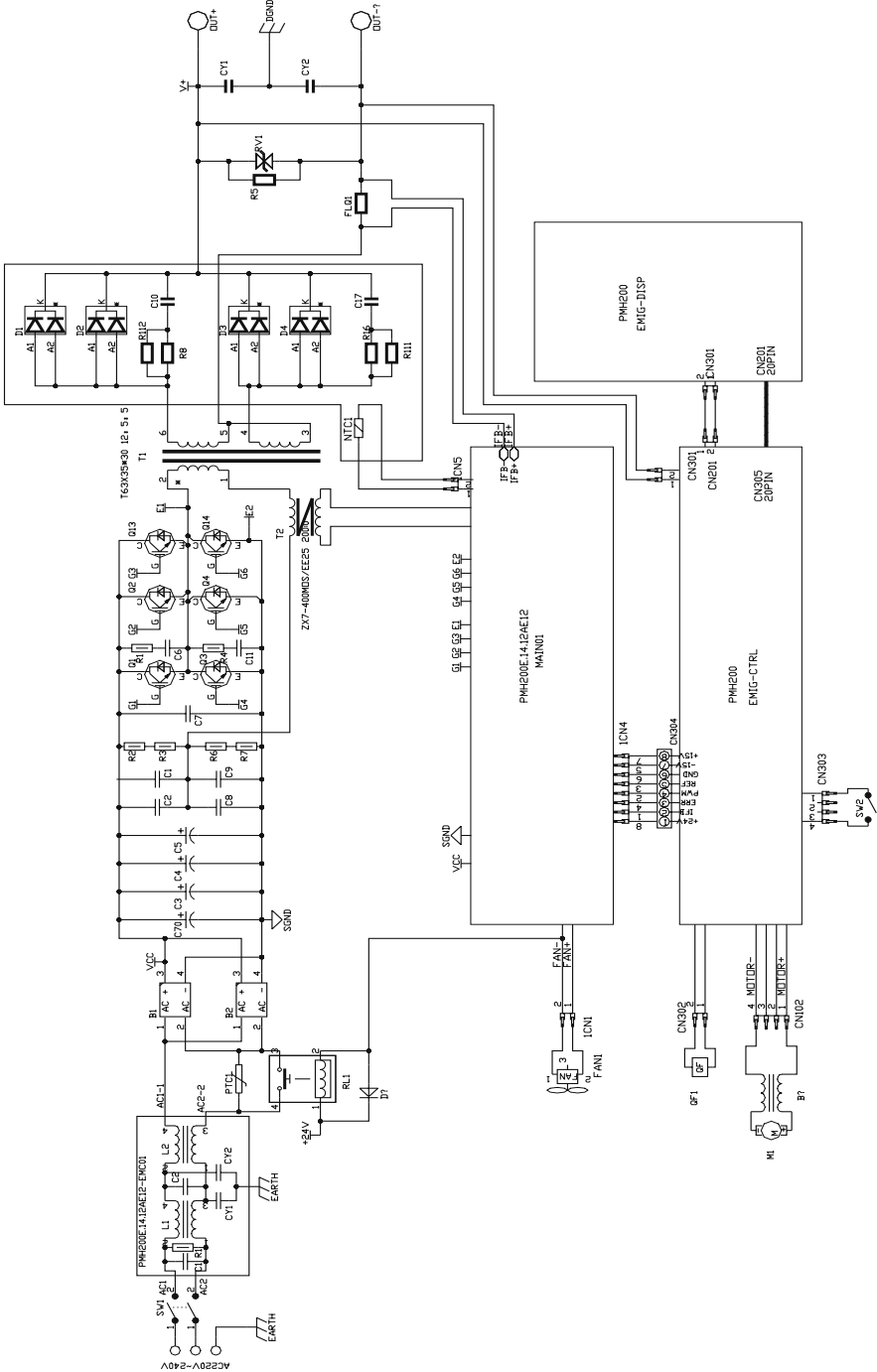

# PARTS BREAKDOWN

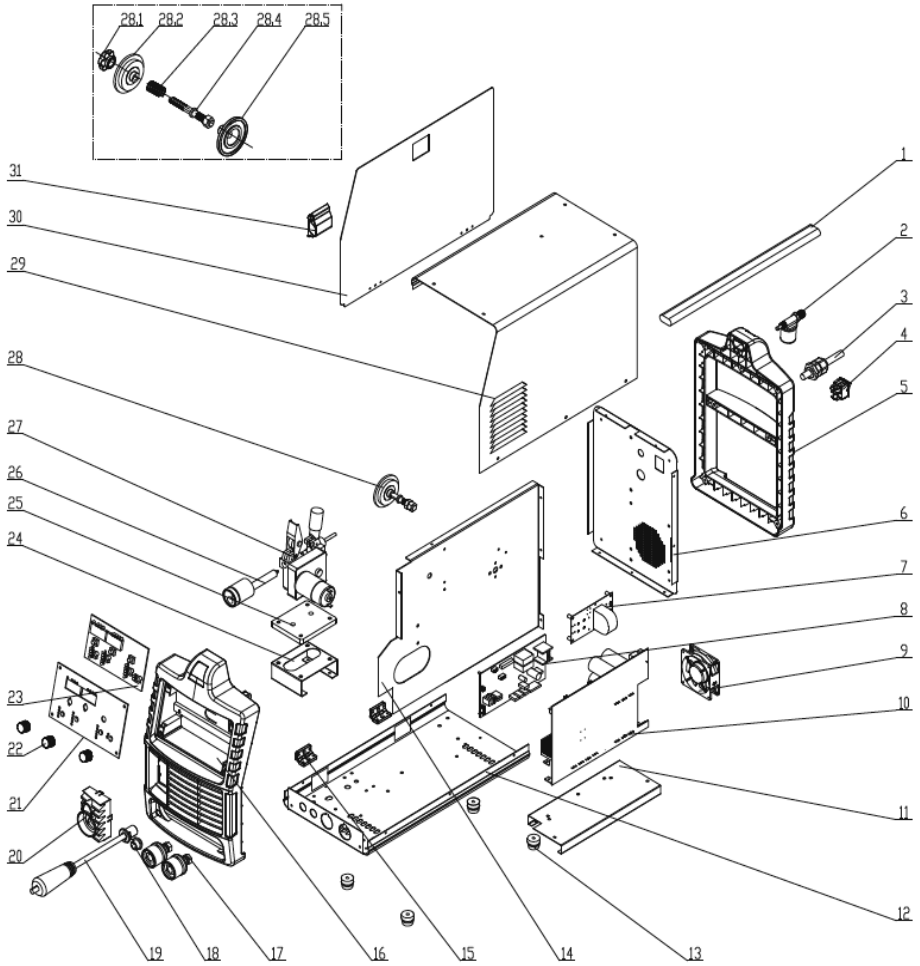

<b>No.</b>	<b>Description</b>	<b>Part number</b>	<b>Qty</b>
1	Handle	20020170016	1
2	Valve wires	12070024136	1
3	Power line	11120260022	1
4	Switch	20070800015	1
5	Plastic back panel	20050050426	1
6	Back panel	12020110903	1
7	EMC board	11050110512	1
8	Control PCB board	11050070485	1
9	Fine wires	11100260066	1
10	Main control board	11050021102	1
11	Main panel support board	11020010571	1
12	Sheet metal case base	12010040856	1
13	Feet	20050050542	4
14	Vertical center sheet metal	11010050033	1
15	Hinge	20050050089	2
16	Plastic front panel	20050050425	1
17	Quick Connector	20070570197	2
18	switch socket	20030301407	1
19	Umpolung cable	12070030151	1
20	Flange plate	20050050378	1
21	Front panel support	11020014191	1
22	Potentiometer Knob	20070110054	3
23	Front panel Control Board	11050070487	1
24	Fixed plate of wire feeder	11020014111	1
25	Subplate of wire feeder	11020014212	1
26	Central socket	12070020816	1
27	Wire feeder	20070400137	1
28	Scroll roller	12020160812	1
28.1	Adjustable nut	20050050316	1
28.2	Adjustable handle	20050050315	1
28.3	Spring	20060290020	1
28.4	Bolt	20050050317	1
28.5	Fixed handle	20050050314	1
29	Case	11010010694	1
30	Duplicate	11010020890	1
31	Bolt	20080070004	1

## NOTES:

**NOTES:**



## WARRANTY INFORMATION

This warranty is provided by Total Tools (Importing) Pty Ltd 20 Thackray Road, Port Melbourne, VIC 3207 (we, us, our).

### Express warranty

Subject to the exclusions set out below, we warrant that this product will be free from defects in materials or workmanship for a period of 12 months from the date of purchase. The benefits conferred by this warranty are in addition to all rights and remedies which you may be entitled to under the Australian Consumer Law, and any other statutory rights you may have under other applicable laws. This warranty does not exclude, restrict or modify any such rights or remedies.

### Warranty exclusions

This express warranty does not apply where a defect or other issue with the product is caused by normal wear and tear, misuse or abuse of the product.

### Consumer guarantees

Our goods come with guarantees that cannot be excluded under the Australian Consumer Law. You are entitled to a replacement or refund for a major failure and for compensation for any other reasonably foreseeable loss or damage. You are also entitled to have the goods repaired or replaced if the goods fail to be of acceptable quality and the failure does not amount to a major failure.

### Warranty claims

To make a claim under this warranty, you must bring the product along with the proof of purchase and any other documentary evidence which you think is relevant to the Total Tools' place of purchase where the claim will be handled on our behalf. Any cost incurred by you in bringing the product to the place of purchase will be borne by you.

To make a claim under this warranty, the product and proof of purchase must be returned to the Total Tools place of purchase during the warranty period specified above. If your warranty claim is accepted, we (or the Total Tools store that handles the claim on our behalf) will, at our discretion, repair or replace the product, or refund money to you and take back the product.

<b>MULTI80 POWER SOURCE</b>	<b>Warranty Period</b>
Original main Transformer	1 Year
Original main power rectifiers, printed circuit boards and power switch semiconductors	2 Year
<b>MULTI180 ACCESSORIES</b>	<b>Warranty Period</b>
Electrode holder, earth clamp and cables	3 months